

# CLA Coupé and Shooting Brake



Mercedes-Benz



# Rock. Star.

Spotlight on. The tension is rising. The countdown has begun. Get ready for the big event starring the CLA Coupé and CLA Shooting Brake. Hip spots in the city take centre stage – quiet side streets form the backstage area. Enjoy an exclusive meet & greet with the most exciting vehicles in their segment.

THEY ROCK IN ANY FORMAT.



Discover the new CLA Coupé and the new CLA Shooting Brake on your iPad®. The Mercedes-Benz brochure app with lots of additional content is available for free at the iTunes Store®.

## Introducing the band:

### 4 | Mercedes-Benz CLA 250 Coupé polar silver

AMG Line design and equipment line, multi-spoke light-alloy wheels, AMG Exclusive package, RED CUT leather upholstery in black, light longitudinal-grain aluminium trim

### 14 | Mercedes-Benz CLA 200 d 4MATIC Shooting Brake cavansite blue

Urban design and equipment line, 5-twin-spoke light-alloy wheels, Exclusive package, nut brown leather upholstery, aluminium trim with dark honeycomb grain

### 64 | Mercedes-AMG CLA 45 4MATIC Shooting Brake cavansite blue

AMG Night package, AMG cross-spoke light-alloy wheels, upholstery in ARTICO man-made leather/DINAMICA microfibre, AMG Performance seats, AMG trim in black DINAMICA microfibre

### 70 | Mercedes-AMG CLA 45 4MATIC Coupé cirrus white

AMG Aerodynamics package, AMG Night package, AMG cross-spoke light-alloy wheels, upholstery in ARTICO man-made leather/DINAMICA microfibre, AMG Performance seats, black/red trim in AMG design

## The repertoire:

26 | Mercedes me

30 | Services

34 | Engines

36 | 7G-DCT dual clutch transmission

37 | 4MATIC

38 | Active Brake Assist

39 | Integral safety concept

40 | Mercedes me connect

41 | Multimedia systems

42 | Panoramic sliding sunroof

43 | Ambient lighting

48 | Optional extras

50 | Equipment and packages

57 | Genuine accessories

58 | CLA 250 Sport and CLA 250 Sport 4MATIC

60 | Wheels

62 | Mercedes-AMG models

82 | Technical data, dimensions, upholstery, trim and paintwork





The new-generation rock stars: hardly anyone has more followers. No wonder – the sporty design has been revamped once again. The connectivity options have been broadened. Virtuoso road performance – courtesy of powerful and efficient engines, DYNAMIC SELECT (available for certain models) and optional suspension with Adaptive Damping System.

# Bad boy

in good shape.

A selfie with the CLA Coupé is an absolute must. Snap that bumper with the new front apron and bottom trim in silver, black or chrome and the diamond grille. 45.7 cm (18-inch) light-alloy wheels in new designs guarantee more likes.







The CLA Coupé would never dream of fleeing from paparazzi. Why should it? Its avant-garde design sets new benchmarks. The dynamic Coupé profile and the muscular rear with integrated tailpipe finishers and optional LED tail lights make their mark wherever the CLA roams. But it is also happy to put others in the limelight: with its optionally available LED High Performance headlamps.





# Love & pace.

What a rip-roaring ride! With DYNAMIC SELECT (available for certain models), select “Sport” transmission mode and tighten your seat belt. In front of you lies much more than an everyday trip from A to B. Follow your own rhythm as you take bend after bend. The optionally available suspension with Adaptive Damping System offers a tauter set-up for markedly more agile handling.









The Coupé with that special glamour factor: savour the interior honed with fine chrome elements and the new seat covers from the optional Urban line and the optional Exclusive package. The 20.3 cm (8-inch) Media Display available for the multimedia systems rounds off this perfectly composed scenario with a thin frame in chrome look.





# More heartbeats

per minute.

# Access

all areas.

The CLA Shooting Brake is always a class act, whatever the venue. Featuring a standard-fit diamond grille, the bumper with new trim strip, a revamped front apron and the new vehicle colour cavansite blue. Want to take a look backstage? With the HANDS FREE ACCESS option, the tailgate on the CLA Shooting Brake opens and closes fully automatically. In conjunction with the optional KEYLESS-GO comfort package, all it takes is a kicking gesture under the rear bumper.











Don't drive.

Perform.



The CLA's performance gathers standing ovations all along the ideal line. And the new BlueEFFICIENCY Edition models which are kinder on the environment even have Mother Nature applauding.





Get up close to the CLA. With the optionally available Smartphone Integration package including Apple CarPlay™ and Android Auto you can link up directly with your vehicle. This allows you to enjoy selected apps from your smartphone, your music collection and much more besides in the new CLA. Welcome to the VIP area.



# Security

service.

Innovative assistance systems attend to your safety around the clock. The optionally available DISTRONIC Distance Pilot is able to maintain a safe distance from the vehicle ahead automatically, for example. ATTENTION ASSIST detects typical symptoms of drowsiness and can warn the driver of an impending danger of microsleep. The CLA also reveals its reassuring side when it comes to manoeuvring in and out of parking spaces, the optional reversing camera providing assistance here with dynamic guide lines.









Sexiest cars  
alive.





## Our next great innovation revolves around you.

Prepare to be inspired, surprised and thrilled by new services, products and experiences at [www.mercedes.me](http://www.mercedes.me). You are also warmly invited to check out our Mercedes me stores in major cities such as Hamburg, Munich, Milan, Moscow, Tokyo or Hong Kong.





## Mercedes me. Welcome to your Mercedes-Benz world.

You have new questions, Mercedes-Benz has a new answer for you: Mercedes me. Your point of access to a fascinating world of personalised services from Mercedes-Benz. Offering innovative, individualised mobility, connectivity, finance and other services, as well as special brand experiences. All subject to continual development. Innovative, simple and cutting-edge: [www.mercedes.me](http://www.mercedes.me)

Join us – on your smartphone, tablet or PC. And let's shape tomorrow's world together. Any time, anywhere.

**Mercedes me connect** is all about networking the vehicle with the driver – and more besides: the car is becoming part of the way we live, providing added comfort as well as the reassurance of being permanently connected, even while on the move. Mercedes me connect includes Standard Services, which are able to provide you with automatic support in the event of a breakdown or an accident, and Remote Online Services – the option enabling vehicle settings to be carried out by smartphone – and lots more.



**Mercedes me finance** offers you various routes to your vehicle of choice. Mercedes-Benz Financial Services finds the ideal leasing, financing and insurance solution together with you – tailored to your needs. Our leasing products enable you to drive the latest models at all times while enjoying maximum flexibility, as you pay not for acquisition of the vehicle, but only for its use. You also benefit from attractive monthly instalments. Our financing arrangements enable you to pay for your new Mercedes-Benz in a way that suits your personal budget. You can tailor your monthly instalments to your needs by deciding on an appropriate down-payment and term for your contract. Our individual insurance solutions offer reliable protection for your budget and your vehicle on attractive terms. Once a contract is in place, you can conveniently manage your finance applications online.<sup>1</sup>

**Mercedes me inspire** offers special brand experiences and an opportunity to engage in an inspiring dialogue. We aim to share our ideas with you and we would like to know your ideas and wishes. So that we can always offer you the best solutions. A community is available to this end, and you will also find a growing range of offerings and experiences which go beyond the traditional vehicle-related topics – from areas such as events, travel and lifestyle.

**Mercedes me move** offers access to the intelligent mobility solution moovel: this mobility app pools the offerings from various mobility providers to find the ideal route from A to B. car2go is the pioneer and market leader worldwide in free-floating car sharing, and car2go black stands for smartphone-based car sharing with Mercedes-Benz B-Class vehicles. With the mytaxi app you can order a taxi, track its approach live and pay for your journey in a convenient manner.

**Mercedes me assist** makes easy work of organising maintenance for your vehicle, providing a convenient online means of locating a Mercedes-Benz dealer in your neighbourhood and arranging a service appointment. The digital service report keeps you up to date on performed service work at all times. The report is available to you online just one day after a service. In addition to the current service report, you can also view your vehicle's complete service history and service intervals, and you can print this information out if you so wish.

<sup>1</sup> Depending on market availability.

**Mercedes-Benz  
Service**





# Our service: the perfect fit for your Mercedes.

Beyond the car itself, you also acquire something priceless – an exclusive partnership with Mercedes-Benz. For you, this means safety, independence and motoring free of any worries. In other words: the reassuring feeling of driving a Mercedes.

**The best for your Mercedes.** No-one knows your Mercedes better than our experienced specialists at the Mercedes-Benz workshops. The comprehensive range of services and the high standard of quality ensure that your vehicle is in top condition. We use tested Mercedes-Benz GenuineParts and special tools to this end.

**The best for you.** Motoring free of any worries right from the word go: with the tailor-made Mercedes-Benz Service Contracts. These offer you the benefits of a reliable basis for long-term planning, permanent control over costs, fixed monthly rates and cost transparency. Plus ideal protection from additional workshop costs.

**The best for your mobility.** The Mercedes-Benz Mobilo<sup>1</sup> insurance package provides for motoring free of any worries throughout Europe – covering breakdowns, accidents, minor mishaps and vandalism. The benefits offered by Mobilo include on-the-spot assistance, a replacement vehicle, towing and overnight hotel accommodation, for example. This mobility guarantee is automatically on board for the first two years after initial registration, and can subsequently be renewed for a period of up to 30 years in all. Whenever you need assistance, you can reach us free of charge throughout Europe on 00800 1 777 7777<sup>2</sup>.

↘ **FIND OUT MORE**

For the full information on Mercedes-Benz Service Contracts, go to [www.mercedes-benz.com/servicevertraege](http://www.mercedes-benz.com/servicevertraege) – or ask your authorised Mercedes-Benz dealer to draw up an individual offer for you.

<sup>1</sup> Our general terms and conditions apply. The period of validity is extended after each service carried out by an authorised Mercedes-Benz service partner until the due date for the next service – up to a maximum of 30 years after initial registration. <sup>2</sup> Roaming charges may apply when calling from abroad.

## What would motorsport be without Mercedes-Benz?

The first vehicle to ever win an automobile race was powered by a Daimler engine. The first Mercedes was a racing car. The Silver Arrows – a true legend. Mercedes-Benz has a long tradition of involvement with the world of sport. Motorsport shapes the brand and every vehicle bearing the Mercedes star to this day. Discover the brand's unique history first-hand: at the Mercedes-Benz Museum in Stuttgart.

### ↘ FIND OUT MORE

Discover just what has been moving the world for 130 years and take a journey through time as well as through the history of the automobile at the Mercedes-Benz Museum. More than 1500 exhibits await you on 16,500 m<sup>2</sup> of floorspace, including unique gems such as the oldest surviving Mercedes from 1902 or the legendary gull-wing models. Welcome to a place of innovation:

[www.mercedes-benz.com/museum](http://www.mercedes-benz.com/museum)

[www.facebook.com/mercedesbenzmuseum](https://www.facebook.com/mercedesbenzmuseum)

[www.instagram.com/mercedesbenzclassic](https://www.instagram.com/mercedesbenzclassic)

[www.twitter.com/mb\\_museum](https://www.twitter.com/mb_museum)

[www.google.com/+mercedesbenzmuseum](https://www.google.com/+mercedesbenzmuseum)

[www.youtube.com/mercedesbenzmuseum](https://www.youtube.com/mercedesbenzmuseum)



## What would Mercedes-Benz be without motorsport?

3 June 1934 marked the beginning of the Silver Arrows legend in the International Eifel Race at the Nürburgring. Today this legend is more alive than ever: in 2015 the Silver Arrows works team MERCEDES AMG PETRONAS won the Formula 1 constructors' and drivers' titles for the second year in a row. The value of these successes extends way beyond the race track: every mile raced advances the development of lightweight materials and hybrid technology, among other things, for series production.

### ↘ FIND OUT MORE

Fascinating Formula 1 goes multimedia:

[www.facebook.com/MercedesAMGF1](http://www.facebook.com/MercedesAMGF1)

[www.twitter.com/MercedesAMGF1](http://www.twitter.com/MercedesAMGF1)

[www.youtube.com/MercedesAMGF1](http://www.youtube.com/MercedesAMGF1)

[www.plus.google.com/+MercedesAMGF1](http://www.plus.google.com/+MercedesAMGF1)

[www.instagram.com/MercedesAMGF1](http://www.instagram.com/MercedesAMGF1)

[www.MercedesAMGF1.com](http://www.MercedesAMGF1.com)

[www.mercedes-benz.com/motorsport](http://www.mercedes-benz.com/motorsport)



## Famous for economy and fun at the wheel.

### Surefire hits: the efficient diesel engines.

The **4-cylinder diesel engines** go easy on fuel consumption, emissions and noise while putting in a lively performance right from the low rev range. There is a choice of three output ratings ranging from 80 to 130 kW. It goes without saying that the CLA 180 d BlueEFFICIENCY Edition, the CLA 200 d and the CLA 220 d all meet the requirements of the Euro 6 emission class. With the fourth generation of common-rail diesel technology, the engines feature a higher injection pressure of 2000 bar (CLA 180 d: 1600 bar), optimised combustion chambers and precision magnetic valve injectors (CLA 180 d: piezo injectors). A high injection pressure and turbocharging with a variable nozzle turbine ensure a superior torque curve.

### A unique feat of engineering: the petrol engines.

The **4-cylinder petrol engines** such as feature on board the CLA 180 Coupé BlueEFFICIENCY Edition, for example, boast direct petrol injection, variable valve timing and turbocharging, and perform sterling work. These engines also meet the requirements of the Euro 6 emission class. The Mercedes-Benz third-generation high-pressure direct injection with precise piezo injectors and the enhanced spray-guided combustion process enable virtually total combustion and thus higher efficiency, which means that the fuel is used more efficiently. Variable valve control

results in an optimum cylinder charge level, yielding subsequent consumption benefits, which also come courtesy of the lower weight, less internal friction and on-demand ancillaries. The turbocharging enables an immediate response as well as high torque across the whole engine speed range.

### Star saver: courtesy of the ECO start/stop function.

The diesel and petrol engines all have an **ECO start/stop function** which switches off the engine temporarily when the vehicle is stationary. For more efficient driving, the **standard-fit ECO display** featuring improved presentation of information in the instrument cluster indicates how economically the vehicle is being driven at any given moment. This information can be used to help the driver adopt a driving style which provides for optimum fuel consumption in the given driving situation.

#### ↘ FIND OUT MORE

You can find all the technical data on the CLA Coupé and the CLA Shooting Brake on pages 82–83.

#### THE ENGINE RANGE

##### Diesel:

CLA 180 d BlueEFFICIENCY Edition with an output of 80 kW (109 hp) and peak torque of 260 Nm

CLA 180 d with an output of 80 kW (109 hp) and peak torque of 260 Nm

CLA 200 d with an output of 100 kW (136 hp) and peak torque of 300 Nm

CLA 200 d 4MATIC with an output of 100 kW (136 hp) and peak torque of 300 Nm

CLA 220 d with an output of 130 kW (177 hp) and peak torque of 350 Nm

CLA 220 d 4MATIC with an output of 130 kW (177 hp) and peak torque of 350 Nm

##### Petrol:

CLA 180 BlueEFFICIENCY Edition with an output of 90 kW (122 hp) and peak torque of 200 Nm (CLA Coupé only)

CLA 180 with an output of 90 kW (122 hp) and peak torque of 200 Nm

CLA 200 with an output of 115 kW (156 hp) and peak torque of 250 Nm

CLA 220 4MATIC with an output of 135 kW (184 hp) and peak torque of 300 Nm

CLA 250 with an output of 155 kW (211 hp) and peak torque of 350 Nm

CLA 250 4MATIC with an output of 155 kW (211 hp) and peak torque of 350 Nm

CLA 250 Sport with an output of 160 kW (218 hp) and peak torque of 350 Nm (CLA Coupé only)

CLA 250 Sport 4MATIC with an output of 160 kW (218 hp) and peak torque of 350 Nm

Mercedes-AMG CLA 45 4MATIC with an output of 280 kW (381 hp) and peak torque of 475 Nm



### CLA 200 d

Peak torque isn't everything. Only when it makes its presence felt as early on as in the CLA does it facilitate low engine speeds and supremely superior driving.

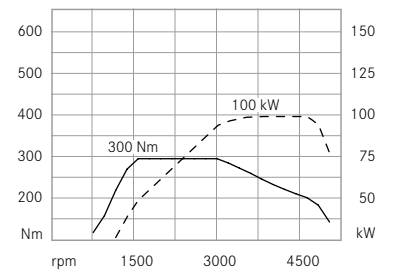

Engine speed (rpm)  
Torque in Nm  
Output in kW



## From “piano” to “forte”: the 7G-DCT.

The seven-speed **7G-DCT dual clutch transmission** combines the comfort of a 7-speed automatic transmission with the driving dynamics of a manual transmission. The 7G-DCT consists of two sub-transmissions, one of which transfers the tractive power to the wheels while the other is preselecting the next gear. This leads to fast, smooth gear changing without any interruptions in tractive power and results in improved acceleration.

The “Economy”, “Sport” and “Manual” transmission modes cover a choice of gearshift characteristics ranging from economical to sporty. When the kickdown function is used in “Sport” mode, the 7G-DCT skips individual gears. This enables faster sprints. Drivers with sporty inclinations can change gear manually using the steering-wheel gearshift paddle.

In conjunction with the 7G-DCT, cruise control, SPEEDTRONIC variable speed limiter and the DYNAMIC SELECT transmission modes also feature as standard.

### MANUAL TRANSMISSIONS

---

The 6-speed manual transmission is perfectly tuned to the respective engine variant and provides for extreme ease of shifting, precise shift travel and a smooth gear change sequence. It also promotes fuel-efficient and comfortable motoring at low engine speeds.

---



## Ready for a breath-taking performance.

The **all-wheel drive system 4MATIC** (see illustration) flawlessly transfers the forwards thrust of the engine and transmission to the road, courtesy of infinitely variable torque distribution for the front axle (between 100% and 50%) and the rear axle (between 0% and 50%) via an electro-hydraulically controlled multi-disc clutch integrated in the rear axle. As a result, the all-wheel-drive system is able to adapt flexibly to the given driving conditions.

It is supported by suspensions offering different characteristics – from comfortably sporty to emphatically sporty. The optionally available **suspension with Adaptive Damping System** enables the driver to choose between comfort and sport mode via the **DYNAMIC SELECT** switch. As the damping system is infinitely variable and the set-up is adjusted for each individual wheel, driving safety and ride quality are also improved.

---

### THE SUSPENSION OPTIONS AT A GLANCE

The **comfort suspension** reduces rolling and pitching, providing for a good balance between comfort and dynamism.

The **suspension with Adaptive Damping System** offers a choice between a more comfort-oriented or a tauter, sportier damping set-up.

The **sports suspension** (available in conjunction with AMG Line) supports a sportier driving style.

The **Sports Direct-Steer system** facilitates more agile vehicle response and increases straight-line stability.

---

## More bodyguards. Fewer dangers.

Foresighted drivers reckon with unforeseen occurrences on every route. Mercedes-Benz Intelligent Drive supports them here and relieves the strain on the driver with intelligent safety and assistance systems.

The CLA features **Active Brake Assist** as standard, for example. This system gives the driver a visual warning about an insufficient distance to vehicles in front. If the distance continues to decrease, an acoustic warning is additionally sounded. If the driver brakes, the Adaptive Brake Assist can build up precisely the braking power required to prevent a collision. If there is no reaction from the driver, in the event of an impending rear-end collision Active Brake Assist can perform autonomous braking in order to prevent a collision or lessen its consequences.

### ↘ FIND OUT MORE

Full information on Mercedes-Benz Intelligent Drive for computer, tablet or smartphone is available at [www.mercedes-benz-intelligent-drive.com](http://www.mercedes-benz-intelligent-drive.com)

The Guidelines for Rescue Services ensure that rescue teams at the accident site always have the latest vehicle data at their disposal. For the full details, go to [www.mercedes-benz.de/rettungsleitfaden](http://www.mercedes-benz.de/rettungsleitfaden)

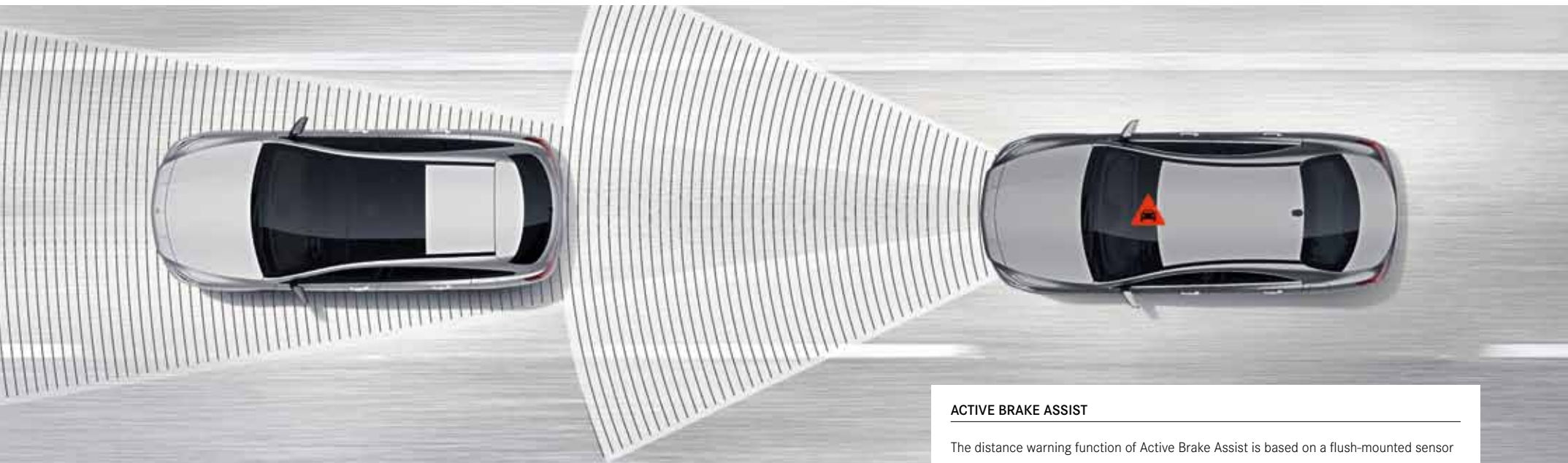

### ACTIVE BRAKE ASSIST

The distance warning function of Active Brake Assist is based on a flush-mounted sensor in the vehicle's front end which continuously monitors the distance from the vehicle in front within a speed range from 7 to 250 km/h. Stationary obstacles can be registered when the vehicle is moving at a speed between 7 and 70 km/h.



# The reassuring feeling of driving a Mercedes-Benz.

We are the first automotive manufacturer worldwide to have developed an **integral safety concept**. In order to avoid accidents, to react appropriately to dangerous situations and to minimise the consequences of accidents. For the occupants of a Mercedes and for all other road users, too.

## SAFE DRIVING

---

The **ATTENTION ASSIST drowsiness detection system** serves to enhance driving safety, in particular on long trips and during night-time driving. It monitors the driver's steering behaviour to detect typical signs of drowsiness and severe loss of attention, and gives a visual and audible warning of impending microsleep.

The optional **DISTRONIC Distance Pilot** helps to maintain a safe distance from the vehicle in front. The system is able to brake the vehicle automatically and subsequently accelerate again as appropriate to the traffic situation.

## IN THE EVENT OF DANGER

---

When a danger of a rear-end collision arises, **Active Brake Assist** is able to initiate autonomous braking in order to avoid a collision or to mitigate the consequences.

The optional **Blind Spot Assist** system employs radar sensors and can draw attention to one of the most serious sources of danger in road traffic. If another road user is detected in the blind spot area, a red triangle appears in

the relevant exterior mirror. When an indicator is actuated, an additional acoustic warning can be output. The system is active between 30 km/h and the vehicle's top speed. Optional **Lane Keeping Assist** is able to recognise when the vehicle is unintentionally drifting out of its lane at speeds between 60 and 200 km/h, duly warning the driver by means of pulsed vibrations on the steering wheel.

The optionally available **PRE-SAFE® occupant protection system** is able to identify critical driving situations in advance and to initiate precautionary measures to protect the vehicle's occupants if there is a risk of an accident. Such measures include reversible belt tensioning or automatic closing of open side windows, for example.

## IN AN ACCIDENT

---

Extensive and intelligently matched **restraint systems** and the structure of the vehicle bodyshell can significantly reduce the risk of injury. Such systems include 3-point seat belts with pyrotechnic belt tensioners and belt force limiters. Numerous airbags are able to ensure optimum all-round protection of the occupants in an accident: for example,

front airbags for the driver and front passenger, each with two-stage deployment in accordance with the registered severity of the impact, sidebags for the driver and front passenger plus windowbags between the A- and C-pillars.

## AFTER AN ACCIDENT

---

Every Mercedes-Benz is perfectly trained in first aid. If the worst comes to the worst, the engine can be switched off automatically and the central locking unlocked, and in addition the hazard warning lamps and the emergency interior lighting can be activated. Finally, the **Mercedes-Benz emergency call system** forming part of the Mercedes connect Standard Services (standard equipment) can send GPS position data and important vehicle information – though this will hopefully never be necessary.



## Moving to a brand-new sound.

We have a name for innovative mobility, connectivity and services: Mercedes me. As part of this Mercedes-Benz world of experience, **Mercedes me connect** fully integrates driver, car and personal lifestyle. Mercedes me connect Standard Services such as the Mercedes-Benz emergency call system or Breakdown Management offer immediate assistance.

**Remote Online** prepares the vehicle for the use of further – separately available – Mercedes me services, such as display of the parked vehicle's location. Remote Online is optionally available in conjunction with the standard Audio 20 USB multimedia system and forms an integral part of the optional COMAND Online multimedia system, which opens up the entire world of Mercedes me connect to you – including a browser, navigation with Live Traffic Information (free for three years) and numerous apps. The system features a high-resolution 20.3 cm (8-inch) colour display (optional for Audio 20 USB/Audio 20 CD). The Mercedes me connect services are only activated at your express request, with the exception of the automatically activated Mercedes-Benz emergency call system.

↘ FIND OUT MORE

For the full details, go to [www.mercedes.me/com](http://www.mercedes.me/com)

## Setting the beat for perfect connectivity.

With the optional **Smartphone Integration package** it is possible to integrate an iPhone® into the vehicle via Apple CarPlay™ as well as Android smartphones with Android Auto and to operate them by voice control – certain functions can also be operated via the vehicle controls. The connection to the smartphone allows access to up-to-date software and data such as navigation and traffic information, media (streaming media and IP radio) as well contact data, telephony/FaceTime and messaging.

### EQUALLY SMART

With the optional **Universal Telephony package**, smartphones can be connected to the onboard hands-free system via a universal smartphone cradle in the armrest. The use of the LTE-compatible exterior aerial ensures optimum reception and transmission. In addition, the battery can be charged.

### ↘ FIND OUT MORE

For full information on the apps for optional Audio 20 CD and the optional COMAND Online system, go to <http://apps.mercedes-benz.com>

With the **Digital Owner's Manual** information can be called up directly in the car via the Media Display. And at [www.mercedes-benz.de/betriebsanleitung](http://www.mercedes-benz.de/betriebsanleitung) you can discover the CLA Coupé and the CLA Shooting Brake interactively. Also available as an app for smartphone or tablet.





## Open-air festival.

With its large glazed area, the optionally available electric **panoramic sliding sunroof** ensures a particularly bright and welcoming ambience in the interior. An electric roller sunblind can shade the vehicle interior if the sunlight glare is too strong. In raised position, the glass roof automatically adjusts to three tilt positions to suit the current speed. The glass roof is lowered at high speeds, reducing the noise level and air circulation in the interior. Conversely, it raises itself again at low speeds.

---

### FOR A PERFECT CLIMATE UNDER A CLOSED ROOF

The vehicle interior can be warmed up or ventilated even before the start of the journey with the optional **auxiliary heater** – using a programmable timer or remote control. In winter this eliminates the need for time-consuming scraping of iced-up windows.

Optional **THERMOTRONIC** automatic climate control enables an individual feel-good climate on board – courtesy of two climate zones. Driver and front passenger are able to control the temperature independently of one another. The climate is maintained at the desired level automatically with the aid of sensors.

---



## The light show.

Climb aboard and enjoy the show – with its pleasant, indirect light, the optional **ambient lighting** system featuring twelve colours conjures up a unique sense of wellbeing in the interior. Especially at night, it accentuates the contouring and high quality of the interior, imparts a feeling of comfort and security by conjuring up an impression of spaciousness and reduces dazzle from oncoming traffic. The mood-enhancing effect of the subtle lighting is apparent as soon as you open the doors. Twelve different colours and five dimming levels are available to create individual light moods. The ambient lighting features full LED technology, and is conveniently controlled via the instrument cluster.

### THE FEATURES OF THE AMBIENT LIGHTING SYSTEM

---

Door centre panel illumination by means of LED lighting units in the door pulls

---

Door handle recess illumination

---

Centre console illumination by means of lighting elements beneath the inside rear-view mirror

---

In conjunction with sports seats, illumination of the opening between the front and rear head restraints

---

Footwell lighting in front and rear

---



## The VIP seats.

The standard-fit **sports seats** (see illustration) at the front are characterised by particularly good side support. Distinguishing features are the high seat backs with triple horizontal fluting and a characteristic opening between the backrest and the integral head restraints.

The optional **luxury seats** with triple horizontal fluting and a wider shoulder area can be ordered in ARTICO man-made leather in black or crystal grey for standard-specification models as well as those with the Urban equipment line. For more comfort in the rear seats the CLA Shooting Brake boasts 42 mm more headroom than the CLA Coupé.

---

### FOR EVEN MORE COMFORTABLE SEATS

---

**4-way lumbar support for driver and front passenger** (optional): an adjustable lumbar support enables individual adjustment of the seat backrest contour, thereby enhancing seated comfort and ergonomics.

---

The optional **Seat Comfort package** provides greater seating comfort on longer journeys in particular by equipping the driver's seat and the front passenger seat with even more ergonomic individualisation options.

---

The **electric adjustment option for driver's and front passenger seat** enables convenient and individual adjustment of the seat position.

---

As part of the optional Seat Comfort package, the **seat cushion length adjustment** feature offers a 60 mm wider surface for the thighs, for an even more pleasant travel experience.

---

## The backstage area.

The **load compartment** of the CLA Shooting Brake with its capacity of 495 litres (as much as 595 litres in the cargo position) boasts the greatest width in its class and outstanding depth, variability and functionality. In order to protect the cargo, the integral retractable cover can be pulled over the load. An optionally available dividing net between the luggage compartment and the passenger compartment protects the passengers during the journey.

The high-class appeal of the load compartment can be further enhanced with the three optional **designer aluminium rails** on the load compartment floor. These offer increased slip resistance when transporting goods thanks to their rubber inserts.

### ENOUGH ROOM FOR EXTRAS

The **Load Compartment package** is optionally available for more order, safety, and additional load space. It comprises net pockets, the cargo position function for the rear seat backrests (15° steeper), a 12 V socket and a folding box beneath the load compartment floor (not in conjunction with Harman Kardon® Logic 7® surround sound system).

Effective protection against prying eyes is provided for the luggage compartment in the guise of a pull-out **luggage compartment cover** with a practical roller mechanism.

For convenient loading and unloading, the **EASY-PACK tailgate** on the CLA Shooting Brake opens and closes electromechanically at the push of a button. The optional KEYLESS-GO comfort package enables fully automatic non-contact opening and closing by means of a kicking gesture under the rear bumper.





## The stage outfit: Standard.

How do you top something that's so good in the first place? The standard scope of equipment for the new CLA already boasts numerous extras – though there's still plenty more to discover among the optional extras, of course.

### ↳ FIND OUT MORE

As attractive as this overview may be, it only provides an initial impression. For the complete range of standard equipment please refer to the price list, which is also available for viewing online:

[www.mercedes-benz.com](http://www.mercedes-benz.com)

### EXTERIOR HIGHLIGHTS

10-spoke light-alloy wheels, painted champion silver, with 205/55 R 16 tyres

10-spoke light-alloy wheels, painted titanium silver, with 225/45 R 17 tyres (in conjunction with CLA 220 d, CLA 220 d 4MATIC, CLA 250 and CLA 250 4MATIC)

Diamond radiator grille with pins in black, silver-painted louvre and chrome insert; front apron inlay in matt iridium silver

Two-pipe exhaust system with chromed tailpipe trims (in conjunction with CLA 220 d, CLA 220 d 4MATIC, CLA 250 and CLA 250 4MATIC)

High-gloss black rear apron insert (in conjunction with CLA 220 d, CLA 220 d 4MATIC, CLA 250 and CLA 250 4MATIC)

### INTERIOR HIGHLIGHTS

3-spoke multifunction steering wheel with twelve function buttons

Sports seats upholstered in ARTICO man-made leather/Coari fabric with topstitching

Matrix-look trim

Air vents with surrounds in silver chrome and cruciform nozzle in high-gloss black

High-gloss black light switch with ring in silver chrome

Door centre panels in ARTICO man-made leather with topstitching

Roof lining in grey







## For even more glamour: the optional extras.

Countless options are available to make a CLA Coupé or a CLA Shooting Brake your very own. From small details to special touches and comfort features which until recently were the reserve of the luxury segment. Browse at your leisure – in this catalogue or online.

At [www.mercedes-benz.com](http://www.mercedes-benz.com) you can configure the CLA yourself.



---

**Garmin® MAP PILOT:** This compact navigation module transforms Audio 20 CD into a fully fledged, intuitively operated navigation system. The SD card-based navigation function can be activated by inserting it into the SD card slot in the head unit.

---

The **8-inch Media Display** offers a modern tablet look with a screen diagonal of 20.3 cm.

---

With the **Smartphone Integration package** it is possible to integrate an iPhone® into the vehicle via Apple CarPlay™ as well as Android smartphones with Android Auto and to operate them by voice control. Certain functions can also be operated via the vehicle's controls. This makes safe use possible while on the move.

---

The **EASY-PACK tailgate** on the CLA Shooting Brake can be opened and closed electromechanically with the greatest of ease at the push of a button. To prevent the door from bumping against any objects, it can be stopped in any position and its opening angle can be restricted.

---

The **reversing camera** with dynamic guidelines on the Media Display facilitates parking and manoeuvring. It is switched on automatically when the driver selects reverse gear, and shows the driver the area behind the vehicle with dynamic guide lines on the head unit display.

The driver and front passenger seat are electrically adjustable and have a **Memory function**. This can be used to save and recall up to three settings for the front seats and the exterior mirrors – for enhanced suitability for everyday use.

**THERMOTRONIC** automatic climate control with two climate zones provides individual climate control for the driver and for the front passenger. Temperature, airflow and air distribution are controlled automatically. The temperature can be regulated separately for driver and front passenger.

In addition to their distinctive visual appeal, the **LED High Performance headlamps** boost night-time driving safety thanks to broad light distribution, a daylight-simulating colour temperature and low energy consumption. The tail lights feature LED technology and create a visual highlight while improving visibility.

The **ambient lighting** system available in conjunction with the Light and Sight package impressively showcases the entire interior with twelve different colours and five dimmer settings.

The 450-watt **Harman Kardon® Logic 7® surround sound system** with twelve loudspeakers, including a woofer, and a 9-channel DSP amplifier, combines with audio systems to offer a perfect audio experience in stereo – in conjunction with COMMAND Online, even DTS and Dolby Digital 5.1 formats are possible.

**KEYLESS-GO** enables the vehicle to be conveniently opened, started and locked – simply by having the electronic key on your person. The **HANDS-FREE ACCESS** function allows contactless, fully automatic opening of the boot lid. Both systems form part of the KEYLESS-GO comfort package.







## Everybody's darling in the city: the Urban line.

The Urban design and equipment line offers select interior and exterior details to further sharpen the car's profile. Dynamic touches are added by the new design of the trim on the rear bumper, the diamond radiator grille with pins in high-gloss black and sports seats featuring a new cover design, for example.

### EXTERIOR HIGHLIGHTS

---

5-twin-spoke light-alloy wheels, painted himalayas grey, with 225/40 R 18 tyres

---

Diamond radiator grille in black

---

Twin-pipe exhaust system with chrome-plated tailpipe trim

---

Front and rear apron inlay in chrome look

---

Lowered comfort suspension (no-cost option: comfort suspension)

---

### INTERIOR HIGHLIGHTS

---

New seat covers in three new designs

---

New sail-pattern trim

---

3-spoke leather multifunction steering wheel, with perforated grip areas and twelve function keys, contrasting topstitching

---

Sports seats with upholstery in ARTICO man-made leather/Maringá fabric and contrasting topstitching

---

Seat Comfort package, including seat cushion depth adjustment

---



## For your street performance: The AMG Line.

The AMG Line lends the interior an even sportier feel. On the outside, AMG bodystyling underscores the new CLA's dynamic character.

### AMG PURE

Discover the fascinating world of AMG beginning on page 62.

### EXTERIOR HIGHLIGHTS

---

AMG bodystyling with front and rear apron plus side sill panels

---

AMG 5-twin-spoke light-alloy wheels, painted titanium grey with a high-sheen finish, with 225/40 R 18 tyres

---

Diamond radiator grille with pins in chrome, silver-painted louvre and chrome inserts

---

Twin-pipe exhaust system with chrome-plated tailpipe trim

---

Diffusor insert in body colour with chrome trim, high-gloss black in conjunction with Night package

---

Lowered sports suspension

---

Perforated front brake discs, front brake callipers with "Mercedes-Benz" lettering

---

### INTERIOR HIGHLIGHTS

---

3-spoke multifunction leather sports steering wheel with flattened lower section, perforations in the grip area, twelve function keys and red contrast topstitching

---

Sports seats upholstered in ARTICO man-made leather/DINAMICA microfibre with red contrasting topstitching

---

Seat Comfort package, including seat cushion depth adjustment

---

Light longitudinal-grain aluminium trim

---

Air outlets with surround and cruciform nozzle in silver chrome

---

Brushed stainless-steel sports pedals with rubber studs

---





## For that special touch: the Exclusive package.

Stylishly coordinated for your pleasure: the Exclusive package featuring high-quality interior equipment and appointments meets very high standards with regard to comfort, quality and design.

---

3-spoke multifunction steering wheel in leather, with perforations in grip area and twelve control buttons (flattened bottom section in conjunction with AMG Line)

---

Sports seats with leather upholstery and contrasting topstitching as well as perforated pads

---

Heated seats for driver and front passenger

---

Seat Comfort package

---

4-way lumbar support

---

Dashboard in ARTICO man-made leather with contrasting topstitching

---

Beltlines in ARTICO man-made leather with contrasting topstitching in wrap-around look

---

Aluminium trim with trapezoidal grain

---

Light longitudinal-grain aluminium trim (in conjunction with AMG Line)

---

Black roof liner (option: grey roof liner in conjunction with black leather upholstery)

---

Brushed stainless steel sports pedals with rubber studs (in conjunction with AMG Line)

---

Cord floor mats with edging in the appointments colour

---

12V socket in rear

---

Convenience closing feature with summer opening/closing function for side windows and panoramic sliding sunroof (optional)

---



## Class act: the AMG Exclusive package.

Building on the optionally available AMG Line, we have put together a combination of high-quality interior features for you – for maximum exclusivity, individuality and sportiness.

---

Sports seats with black RED CUT leather upholstery featuring red contrasting topstitching

---

Heated seats for driver and front passenger

---

Seat Comfort package

---

4-way lumbar support

---

Dashboard in ARTICO man-made leather with red contrasting topstitching

---

Aluminium trim with light longitudinal grain

---

3-spoke multifunction leather sports steering wheel with flattened lower section, perforations in the grip area, twelve function keys and red contrast topstitching

---

Beltline in ARTICO man-made leather with red contrasting topstitching in wrap-around look

---

designo seat belts in red (in conjunction with Sport models and Mercedes-AMG CLA 45 4MATIC)

---

Black roof lining

---

Brushed stainless-steel sports pedals with rubber studs

---

Cord floor mats with border in black and topstitching in red with “AMG” lettering (“Sport” lettering in conjunction with Sport models)

---



## For the after-show party: The Night package.

With striking design features in black, the Night package lends the CLA an even sportier, more expressive character – from the new trim strips in the front and rear bumpers through tinted glass, the exterior mirrors and light-alloy wheels to the window surround.

---

Front and rear bumper with trim strip in high-gloss black

---

Exterior mirror housings painted in high-gloss black

---

Heat-insulating dark-tinted glass for all windows from the B-pillar to the rear

---

Beltline trim strip and window frames in high-gloss black

---

Additional features of the Night package in conjunction with Urban line:

10-spoke light-alloy wheels, painted black with a high-sheen finish, with 225/40 R 18 tyres, plus diamond radiator grille with pins in high-gloss black and louvre in high-gloss black with chrome inserts

---

Additional features of the Night package in conjunction with AMG Line: AMG 5-twin-spoke light-alloy wheels, painted black with a high-sheen finish, with 225/40 R 18 tyres, plus diamond radiator grille with pins in chrome, louvre in high-gloss black with chrome insert and high-gloss black diffusor insert in rear apron

---



# All originals: the genuine accessories.

Place your trust in Mercedes-Benz Genuine Accessories and style the CLA Coupé and the CLA Shooting Brake with even more individuality tailored perfectly to your needs.



---

Discreet add-on part attached to the boot lid which unobtrusively accentuates the air-flow breakaway edge on the rear of the CLA Coupé. High-quality priming enables paint finish in customer's choice of colour.

---

Boot tub, shallow, in impact-resistant polypropylene with anti-slip effect

---

5-twin-spoke light-alloy wheels, painted black with red rim flange, with 225/40 R 18 tyres

---

Making your star shine brightly: the star centred in the radiator grille of your Mercedes will light up courtesy of fibre optic and LED technology when the vehicle is unlocked by remote control, and when a door or the boot lid is opened (functions only apply when engine is off, not in conjunction with Distance Pilot DISTRONIC).

---







## CLA 250 Sport and CLA 250 Sport 4MATIC.

What a duet: discover a harmonious composition of uncompromising sportiness and breath-taking exclusivity on board the CLA 250 Sport<sup>1</sup> and CLA 250 Sport 4MATIC. With a sporty engine sound, lowered sports suspension engineered by AMG and AMG bodystyling.

### EXTERIOR HIGHLIGHTS

---

AMG 5-spoke light-alloy wheels, painted black with a high-sheen finish, with 235/40 R 18 tyres (see illustration at bottom right of page 58)

---

AMG speed-sensitive sports steering

---

Diamond radiator grille with pins in chrome, louvre in high-gloss black and chrome inserts

---

Perforated brake discs at the front, red brake callipers at front and rear with "Mercedes-Benz" lettering

---

More sporty engine, transmission and accelerator configuration

---

Modified ESP<sup>®</sup> configuration

---

Red trim on the front and rear aprons

---

### INTERIOR HIGHLIGHTS

---

Sports seats upholstered in ARTICO man-made leather/DINAMICA microfibre with red contrasting topstitching

---

designo seat belts in red (not in conjunction with Exclusive package)

---

Air outlets with surround and cruciform nozzle in silver chrome

---

Cord floor mats with edging in black and contrasting red topstitching as well as "Sport" lettering

---

<sup>1</sup> CLA 250 Sport only in conjunction with CLA Coupé.



## You gotta roll with it. The wheels.

The perfect wheel deal. Find just the wheels to suit you and your very own dream car from our large, attractive selection.

### STANDARD EQUIPMENT AND OPTIONAL EXTRAS

**R00** 10-hole steel wheels with wheel trim, with 195/65 R 15 tyres (standard for CLA Coupé BlueEFFICIENCY Edition models).

**643** 10-hole steel wheels with wheel trim, with 205/55 R 16 tyres (standard for CLA Shooting Brake BlueEFFICIENCY Edition model; optional for CLA Coupé BlueEFFICIENCY Edition models)

**R78** 5-twin-spoke light-alloy wheels, painted matt black with a high-sheen finish, with 205/55 R 16 tyres (optional)

**R20** 7-spoke light-alloy wheels, painted matt black with a high-sheen finish, with 205/55 R 16 tyres (optional)

**39R** 10-spoke light-alloy wheel, painted champion silver, with 205/55 R 16 tyres (standard for CLA 180, 200, 220 4MATIC, 180 d, 200 d, 200 d 4MATIC)

**R24** 5-spoke light-alloy wheels, painted titanium silver, with 225/45 R 17 tyres (optional)

**02R** 5-spoke light-alloy wheels, painted tremolite grey with a high-sheen finish, with 225/45 R 17 tyres (optional)

**R43** 10-spoke light-alloy wheels, painted titanium silver, with 225/45 R 17 tyres (optional; standard for CLA 220 d/220 d 4MATIC and CLA 250/250 4MATIC)

**25R** 10-spoke light-alloy wheels, painted titanium silver, with 205/50 R 17 tyres (optional)

**R31** 5-twin-spoke light-alloy wheels, painted himalayas grey with a high-sheen finish, with 225/40 R 18 tyres (optional)

**46R** 5-triple-spoke light-alloy wheels, painted tremolite grey, with 225/40 R 18 tyres (optional)

**66R** 5-twin-spoke light-alloy wheels, painted himalayas grey, with 225/40 R 18 tyres (standard in conjunction with Urban line)

**51R** 10-spoke light-alloy wheels, painted tremolite grey with a high-sheen finish, with 225/40 R 18 tyres (optional)

**05R** 10-spoke light-alloy wheels, painted black with a high-sheen finish, with 225/40 R 18 tyres (optional)



## AMG

678 AMG 5-twin-spoke light-alloy wheels, painted titanium grey with a high-sheen finish, with 225/40 R 18 tyres (standard in conjunction with AMG Line)

612 AMG 5-twin-spoke light-alloy wheels, painted black with a high-sheen finish, with 225/40 R 18 tyres (optional)

791 AMG multi-spoke light-alloy wheels, painted titanium grey with a high-sheen finish, with 225/40 R 18 tyres (optional)

760 AMG multi-spoke light-alloy wheels, painted titanium grey with a high-sheen finish, with 225/40 R 18 front tyres and 245/35 R 18 rear tyres (optional)<sup>1</sup>

646 AMG multi-spoke light-alloy wheels, painted black with a high-sheen rim flange, with 225/40 R 18 tyres (optional)

796 AMG multi-spoke light-alloy wheels, painted black with a high-sheen rim flange, with 225/40 R 18 front tyres and 245/35 R 18 rear tyres (optional)<sup>1</sup>

756 AMG 10-spoke light-alloy wheels, painted titanium grey with a high-sheen finish, with 235/40 R 18 tyres (standard for Mercedes-AMG CLA 45 4MATIC)

637 AMG 5-twin-spoke light-alloy wheels, painted black with a high sheen finish, with 235/40 R 18 tyres (optional for CLA 250 Sport and CLA 250 Sport 4MATIC)

693 AMG multi-spoke light-alloy wheels, painted black with a high sheen finish, with 235/35 R 19 tyres (optional for CLA 250 Sport and CLA 250 Sport 4MATIC)

780 AMG multi-spoke light-alloy wheels, painted titanium grey with a high-sheen finish, with 235/35 R 19 tyres (optional for Mercedes-AMG CLA 45 4MATIC)

787 AMG multi-spoke light-alloy wheels, painted matt black with a high-sheen rim flange, with 235/35 R 19 tyres (optional for Mercedes-AMG CLA 45 4MATIC)

638 AMG cross-spoke light-alloy wheels, painted titanium grey with a high-sheen finish, with 235/35 R 19 tyres (optional for Mercedes-AMG CLA 45 4MATIC)

99R AMG cross-spoke light-alloy wheels, painted matt black with a high-sheen rim flange, with 235/35 R 19 tyres (optional for Mercedes-AMG CLA 45 4MATIC)

### ADDITIONAL WHEELS

can be found in our accessories range.

Information on the range of Mercedes-Benz Genuine Accessories is available at [www.mercedes-benz-accessories.com](http://www.mercedes-benz-accessories.com) or from your authorised Mercedes-Benz dealer.

<sup>1</sup> Mixed-tyre variant with different rims and tyre dimensions on the rear axle.

# Driving progress. Mercedes-AMG CLA 45 4MATIC Shooting Brake and Coupé.

Mercedes-AMG is not just a producer of performance vehicles. AMG is a commitment. A commitment to always go that extra mile. To give everything in pursuit of high aspirations. This is how we create exceptional cars for exceptional people.

Built to make an impression. On the city. On people. On the road. The new Mercedes-AMG CLA 45 Shooting Brake and the new Mercedes-AMG CLA 45 Coupé.

Welcome to the world of AMG.

  
DRIVING PERFORMANCE







A blurred Mercedes-AMG CLA 45 Shooting Brake is shown in motion on a road. The car is dark-colored with a prominent front grille and a distinctive front apron. The background features a city skyline with a tall building and power lines under a clear sky.

# Design perfected.

The facelift once again highlights the dynamic character of the Mercedes-AMG CLA 45 Shooting Brake. The striking front is characterised by the AMG radiator grille with twin louvres in silver chrome and the distinctive AMG front apron in A-wing design. The front splitter insert in matt titanium grey and high-gloss black flics improve the flow of cooling air. The new 19-inch cross-spoke light-alloy wheels are a delight to behold in the side view. The aerodynamically optimised rear end rounds off the overall expressive appearance. It's immediately apparent that you're always streets ahead in a compact racer from AMG.

# SHOOTING BRAKE



# Ultimate refinement.

The AMG Performance seats with bolder contours and integrated head restraints are a celebration of high-class materials and sporty elegance. Seat surface and backrest offer even better lateral support while lending the interior a distinctive sporty look. The AMG E-SELECT lever, which now features as standard, and the optional AMG Performance steering wheel with silver-coloured shift paddles add the finishing touches to the interior's dynamic feel. Just buckle up and soar away.



# The drive system par excellence.

AMG is always in the fast lane when it comes to setting standards, too. A prime example is the 2.0-litre engine on board the Mercedes-AMG CLA 45. With a power output of 280 kW (381 hp), this engine makes a big impression in terms of both performance and efficiency. Its NEDC fuel consumption stands at just 6.9 l/100 km, for example. A true masterpiece of engineering, hand-crafted according to the “One Man – One Engine” principle. Embodying a passion for racing that’s a thrill to have at your fingertips. While the AMG sports exhaust system provides an equally thrilling soundtrack.







COUPÉ



# Driving dynamics: the next level.

What's the shape of driving dynamics to come? The AMG DYNAMIC PLUS package on the Mercedes-AMG CLA 45 Coupé. This includes the mechanically controlled AMG front-axle differential lock. For optimum traction in all driving situations. Other features of the package are the AMG Performance steering wheel, the AMG RIDE CONTROL sports suspension with Adaptive Damping System and the RACE transmission mode. The latter lives up to its name: RACE is tuned for maximum driving dynamics and is ideal when you're going all out for best times. On the race track, rather than around the corner on an errand.



## Forward thrust.

The rear end of the Mercedes-AMG CLA 45 Coupé has visibly undergone further development according to the “more thrust, less lift” principle. The new AMG spoiler lip plays a crucial role in improving aerodynamics. The AMG diffuser-look rear apron with four vertical fins additionally optimises the flow of air. The two chromed twin tailpipe finishers of the AMG sports exhaust system and the “TURBO 4MATIC” lettering on the sides add the finishing touches to the vehicle’s overall progressive character. Pure dynamism – the essence of the new CLA 45 Coupé.





# Handling – honed to perfection.

Optimum user-friendliness is crucial to perfect handling. The AMG DRIVE UNIT fits the part here as the control centre for the AMG SPEEDSHIFT DCT 7-speed sports transmission and the AMG DYNAMIC SELECT transmission modes, which are simple to operate by means of rotary switches. The AMG high-performance brake system enables excellent deceleration, applying just the required braking power. The AMG Aerodynamics package with larger front splitters and additional flics on the front apron increases negative lift. For easy freewheeling with the AMG light-alloy wheels.



# A drive to thrill.

The development of the 3-stage Electronic Stability Program (ESP®) reconciled the previously contradictory aims of driving enjoyment and safety. Using the ESP® button, the driver can choose one of three different control strategies: “ESP® ON” for a high level of safety, “ESP® SPORT HANDLING MODE” for a sporty driving style and “ESP® OFF” for driving on closed racing circuits. The AMG RIDE CONTROL sports suspension additionally helps in transferring the engine power more effectively to the asphalt. What ever lies ahead, you can rely on your vehicle’s performance.





# Engineering revolution.

What do AMG drivers and AMG engineers have in common? They're all petrolheads. As indicated by the most powerful series-production 4-cylinder turbo engine in the world, delivering an output of 280 kW (381 hp). Its specific output of 141 kW (191 hp) per litre actually puts most super sports cars in the shade. A twin-scroll turbocharger provides for excellent response and the utmost in agility. Up to 475 Nm of torque is on tap to this end.

AMG Performance 4MATIC ensures that the power is ideally distributed to all four wheels. The optional AMG DYNAMIC PLUS package with mechanical controlled front-axle differential lock serves up even greater traction. At some point, your car may well come up against its physical limits. But your driving enjoyment will remain boundless.











Sharing a special passion: the AMG Private Lounge is our community centred around the world of AMG. This is where AMG customers come together at top-class events and on the online platform to exchange views about the latest developments from Affalterbach. They benefit from special offers and a direct link to AMG headquarters: [www.mercedes-amg.com/privatelounge/welcome](http://www.mercedes-amg.com/privatelounge/welcome)

The AMG Driving Academy stands for an incomparable team spirit: experience performance with like-minded drivers and improve your driving skills at racetrack and lifestyle events held at breathtaking locations around the world. Become a part of the “World’s Fastest Family”: [www.mercedes-amg.com/driving-academy](http://www.mercedes-amg.com/driving-academy)

You still want more? With the AMG Customer Sports programme, AMG offers a platform for professional motorsport – and in the Mercedes-AMG GT3 it has a racing car design specifically for this field of use. A fully integrated range of services stands for motorsport to the highest standards: [www.mercedes-amg.com/customersports](http://www.mercedes-amg.com/customersports)

At the AMG Performance Studio we create cars that are perfectly tailored to your wishes and desires. No limits are placed on our experts’ creativity, who demonstrate their unparalleled craftsmanship and attention to detail in areas as varied as special technical components, extravagant paintwork finishes and the most exclusive interior appointments imaginable, to produce one-off masterpieces.

Enter the world of AMG. Experience true driving performance.

We don't just build cars.  
We make dreams come true.

# Technical data for Coupé.

## DIESEL ENGINES

|  | CLA 180 d<br>BE <sup>6</sup> Edition | CLA 180 d                   | CLA 200 d                   | CLA 200 d<br>4MATIC | CLA 220 d           | CLA 220 d<br>4MATIC |
|--|--------------------------------------|-----------------------------|-----------------------------|---------------------|---------------------|---------------------|
| No. of cylinders/arrangement                               | 4/in-line                            | 4/in-line                   | 4/in-line                   | 4/in-line           | 4/in-line           | 4/in-line           |
| Total displacement in cc                                   | 1461                                 | 1461                        | 2143                        | 2143                | 2143                | 2143                |
| Rated output <sup>1</sup> in kW (hp) at rpm                | 80 (109)/4000                        | 80 (109)/4000               | 100 (136)/3200-4000         | 100 (136)/3400-4400 | 130 (177)/3600-3800 | 130 (177)/3600-3800 |
| Rated torque <sup>1</sup> in Nm at rpm                     | 260/1750-2500                        | 260/1750-2500               | 300/1400-3000               | 300/1400-3000       | 350/1400-3400       | 350/1400-3400       |
| Transmission   | 6-speed, manual<br>[-]               | 6-speed, manual<br>[7G-DCT] | 6-speed, manual<br>[7G-DCT] | -<br>[7G-DCT]       | -<br>[7G-DCT]       | -<br>[7G-DCT]       |
| Acceleration from 0 to 100 km/h in s                       | 11.6 [-]                             | 11.6 [11.6]                 | 9.5 [9.0]                   | - [9.0]             | - [7.7]             | - [7.7]             |
| Top speed, approx. in km/h                                 | 190 [-]                              | 205 [205]                   | 220 [220]                   | - [216]             | - [232]             | - [230]             |
| Fuel consumption <sup>3</sup> in l/100 km, combined        | 3.5 [-]                              | 4.0-3.7 [4.2-3.8]           | 4.4-4.0 [4.2-3.8]           | - [4.9-4.6]         | - [4.2-4.0]         | - [4.9-4.6]         |
| CO <sub>2</sub> emissions <sup>3</sup> in g/km, combined   | 89 [-]                               | 108-98 [109-100]            | 114-104 [110-100]           | - [127-119]         | - [111-104]         | - [127-119]         |
| Emission class <sup>4</sup> /efficiency class <sup>5</sup> | Euro 6/A+ [-]                        | Euro 6/A+ [Euro 6/A+]       | Euro 6/A+ [Euro 6/A+]       | - [Euro 6/A]        | - [Euro 6/A+]       | - [Euro 6/A]        |

## PETROL ENGINES

|  | CLA 180<br>BE <sup>6</sup> Edition | CLA 180                     | CLA 200                     | CLA 220<br>4MATIC | CLA 250                     | CLA 250<br>Sport                     | CLA 250<br>4MATIC | CLA 250<br>Sport 4MATIC | Mercedes-AMG<br>CLA 45 4MATIC                            |
|--|------------------------------------|-----------------------------|-----------------------------|-------------------|-----------------------------|--------------------------------------|-------------------|-------------------------|--|
| No. of cylinders/arrangement                               | 4/in-line                          | 4/in-line                   | 4/in-line                   | 4/in-line         | 4/in-line                   | 4/in-line                            | 4/in-line         | 4/in-line               | 4/in-line  |
| Total displacement in cc                                   | 1595                               | 1595                        | 1595                        | 1991              | 1991                        | 1991                                 | 1991              | 1991                    | 1991   |
| Rated output <sup>1</sup> in kW (hp) at rpm                | 90 (122)/5000                      | 90 (122)/5000               | 115 (156)/5300              | 135 (184)/5500    | 155 (211)/5500              | 160 (218)/5500                       | 155 (211)/5500    | 160 (218)/5500          | 280 (381)/6000   |
| Rated torque <sup>1</sup> in Nm at rpm                     | 200/1250-4000                      | 200/1250-4000               | 250/1250-4000               | 300/1200-4000     | 350/1200-4000               | 350/1200-4000                        | 350/1200-4000     | 350/1200-4000           | 475/2250-5000  |
| Transmission   | 6-speed, manual<br>[-]             | 6-speed, manual<br>[7G-DCT] | 6-speed, manual<br>[7G-DCT] | -<br>[7G-DCT]     | 6-speed, manual<br>[7G-DCT] | 6-speed, manual<br>[7G-DCT]          | -<br>[7G-DCT]     | -<br>[7G-DCT]           | - [AMG SPEEDSHIFT<br>DCT 7-speed sports<br>transmission] |
| Acceleration from 0 to 100 km/h in s                       | 9.0 [-]                            | 9.0 [8.7]                   | 8.2 [7.9]                   | - [7.1]           | 6.6 [6.5]                   | 6.5 [6.4]                            | - [6.5]           | - [6.4]                 | - [4.2]  |
| Top speed, approx. in km/h                                 | 190 [-]                            | 210 [210]                   | 230 [230]                   | - [240]           | 240 [240]                   | 250 <sup>2</sup> [250 <sup>2</sup> ] | - [240]           | - [250 <sup>2</sup> ]   | - [250 <sup>2</sup> ]                                    |
| Fuel consumption <sup>3</sup> in l/100 km, combined        | 5.0 [-]                            | 5.7-5.4 [5.6-5.2]           | 5.7-5.5 [5.6-5.2]           | - [6.7-6.5]       | 6.6-6.4 [6.0-5.8]           | 6.7 [6.2]                            | - [6.7-6.5]       | - [6.8]                 | - [7.3-6.9]  |
| CO <sub>2</sub> emissions <sup>3</sup> in g/km, combined   | 117 [-]                            | 133-125 [128-121]           | 133-126 [128-121]           | - [156-152]       | 153-148 [140-136]           | 156 [143]                            | - [156-152]       | - [160]                 | - [171-162]  |
| Emission class <sup>4</sup> /efficiency class <sup>5</sup> | Euro 6/B<br>[-]                    | Euro 6/B<br>[Euro 6/B]      | Euro 6/B<br>[Euro 6/B]      | -<br>[Euro 6/C]   | Euro 6/D<br>[Euro 6/C]      | Euro 6/D<br>[Euro 6/C]               | -<br>[Euro 6/C]   | -<br>[Euro 6/D]         | -<br>[Euro 6/D]  |

**The best for the engine:**  
Mercedes-Benz genuine engine oils.

<sup>1</sup> Figures for rated output and rated torque in accordance with Directive (EC) No. 595/2009 in the currently applicable version. <sup>2</sup> Electronically governed. <sup>3</sup> The figures given for fuel consumption and CO<sub>2</sub> emissions were determined in accordance with the prescribed measuring process (§2 Nos. 5, 6, 6a of the passenger car energy labelling ordinance in the currently applicable version). The figures are not based on an individual vehicle and do not constitute part of the

# Technical data for Shooting Brake.

## DIESEL ENGINES

|  | CLA 180 d<br>BE <sup>6</sup> Edition | CLA 180 d                   | CLA 200 d                   | CLA 200 d<br>4MATIC | CLA 220 d           | CLA 220 d<br>4MATIC |
|--|--------------------------------------|-----------------------------|-----------------------------|---------------------|---------------------|---------------------|
| No. of cylinders/arrangement                               | 4/in-line                            | 4/in-line                   | 4/in-line                   | 4/in-line           | 4/in-line           | 4/in-line           |
| Total displacement in cc                                   | 1461                                 | 1461                        | 2143                        | 2143                | 2143                | 2143                |
| Rated output <sup>1</sup> in kW (hp) at rpm                | 80 (109)/4000                        | 80 (109)/4000               | 100 (136)/3200-4000         | 100 (136)/3400-4400 | 130 (177)/3600-3800 | 130 (177)/3600-3800 |
| Rated torque <sup>1</sup> in Nm at rpm                     | 260/1750-2500                        | 260/1750-2500               | 300/1400-3000               | 300/1400-3000       | 350/1400-3400       | 350/1400-3400       |
| Transmission   | 6-speed, manual<br>[-]               | 6-speed, manual<br>[7G-DCT] | 6-speed, manual<br>[7G-DCT] | -<br>[7G-DCT]       | -<br>[7G-DCT]       | -<br>[7G-DCT]       |
| Acceleration from 0 to 100 km/h in s                       | 11.9 [-]                             | 11.9 [11.9]                 | 9.7 [9.2]                   | - [9.2]             | - [7.8]             | - [7.8]             |
| Top speed, approx. in km/h                                 | 190 [-]                              | 200 [200]                   | 215 [215]                   | - [212]             | - [228]             | - [225]             |
| Fuel consumption <sup>3</sup> in l/100 km, combined        | 3.6 [-]                              | 4.2-3.9 [4.3-4.1]           | 4.4-4.1 [4.2-3.9]           | - [5.0-4.6]         | - [4.3-4.0]         | - [5.0-4.6]         |
| CO <sub>2</sub> emissions <sup>3</sup> in g/km, combined   | 94 [-]                               | 110-101 [114-107]           | 115-108 [111-101]           | - [131-121]         | - [112-105]         | - [131-121]         |
| Emission class <sup>4</sup> /efficiency class <sup>5</sup> | Euro 6/A+ [-]                        | Euro 6/A+ [Euro 6/A+]       | Euro 6/A+ [Euro 6/A+]       | - [Euro 6/A]        | - [Euro 6/A+]       | - [Euro 6/A]        |

## PETROL ENGINES

|  | CLA 180                     | CLA 200                     | CLA 220<br>4MATIC | CLA 250                     | CLA 250<br>4MATIC | CLA 250<br>Sport 4MATIC | Mercedes-AMG CLA 45<br>4MATIC                              |
|--|-----------------------------|-----------------------------|-------------------|-----------------------------|-------------------|-------------------------|--|
| No. of cylinders/arrangement                               | 4/in-line                   | 4/in-line                   | 4/in-line         | 4/in-line                   | 4/in-line         | 4/in-line               | 4/in-line  |
| Total displacement in cc                                   | 1595                        | 1595                        | 1991              | 1991                        | 1991              | 1991                    | 1991   |
| Rated output <sup>1</sup> in kW (hp) at rpm                | 90 (122)/5000               | 115 (156)/5300              | 135 (184)/5500    | 155 (211)/5500              | 155 (211)/5500    | 160 (218)/5500          | 280 (381)/6000   |
| Rated torque <sup>1</sup> in Nm at rpm                     | 200/1250-4000               | 250/1250-4000               | 300/1200-4000     | 350/1200-4000               | 350/1200-4000     | 350/1200-4000           | 475/2250-5000  |
| Transmission   | 6-speed, manual<br>[7G-DCT] | 6-speed, manual<br>[7G-DCT] | -<br>[7G-DCT]     | 6-speed, manual<br>[7G-DCT] | -<br>[7G-DCT]     | -<br>[7G-DCT]           | - [AMG SPEEDSHIFT DCT<br>7-speed sports transmis-<br>sion] |
| Acceleration from 0 to 100 km/h in s                       | 9.1 [8.8]                   | 8.5 [8.2]                   | - [7.2]           | 6.8 [6.7]                   | - [6.6]           | - [6.7]                 | - [4.3]  |
| Top speed, approx. in km/h                                 | 210 [210]                   | 225 [225]                   | - [235]           | 240 [240]                   | - [240]           | - [240]                 | - [250 <sup>2</sup> ]                                      |
| Fuel consumption <sup>3</sup> in l/100 km, combined        | 6.0-5.5 [5.7-5.4]           | 6.0-5.6 [5.7-5.4]           | - [6.9-6.7]       | 6.7-6.6 [6.3-6.1]           | - [6.9-6.7]       | - [6.9]                 | - [7.3-6.9]  |
| CO <sub>2</sub> emissions <sup>3</sup> in g/km, combined   | 140-128 [134-126]           | 140-130 [134-126]           | - [158-154]       | 156-151 [145-141]           | - [158-154]       | - [160]                 | - [171-162]  |
| Emission class <sup>4</sup> /efficiency class <sup>5</sup> | Euro 6/B<br>[Euro 6/B]      | Euro 6/B<br>[Euro 6/B]      | -<br>[Euro 6/C]   | Euro 6/D<br>[Euro 6/C]      | -<br>[Euro 6/C]   | -<br>[Euro 6/D]         | -<br>[Euro 6/C]  |

product offer; they are provided solely for purposes of comparison between different vehicle models. <sup>4</sup>Data applicable within the European Union only. May vary from country to country. <sup>5</sup>Determined on the basis of the measured CO<sub>2</sub> emissions, taking into account the mass of the vehicle.

<sup>6</sup>BlueEFFICIENCY. Figures in square brackets refer to models with automatic transmission. Further technical data can be found at [www.mercedes-benz.com](http://www.mercedes-benz.com)

## Coupé dimensions.

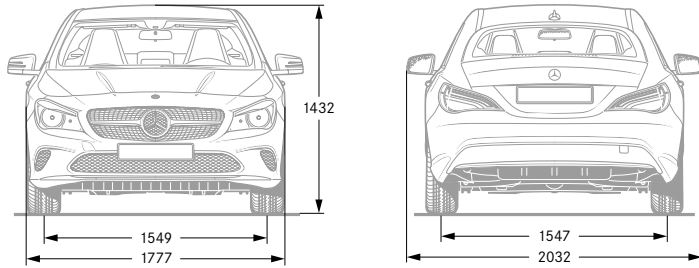

## Shooting Brake dimensions.

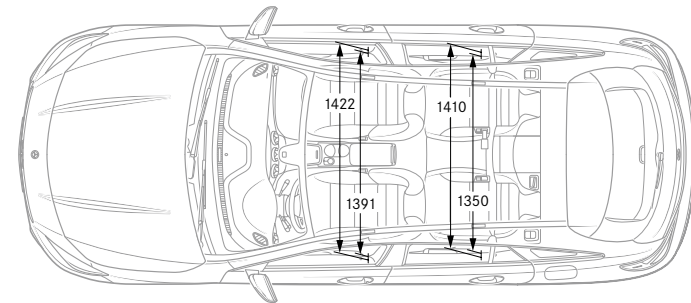
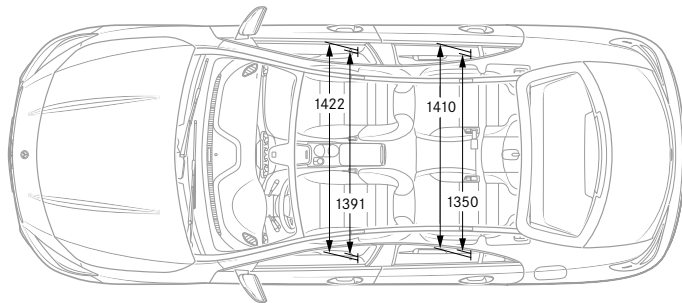
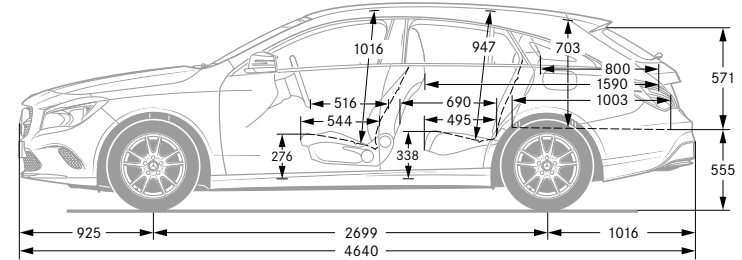
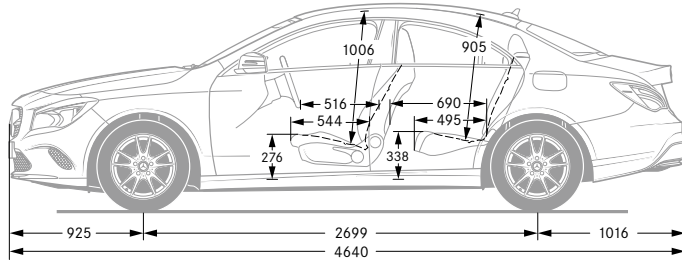
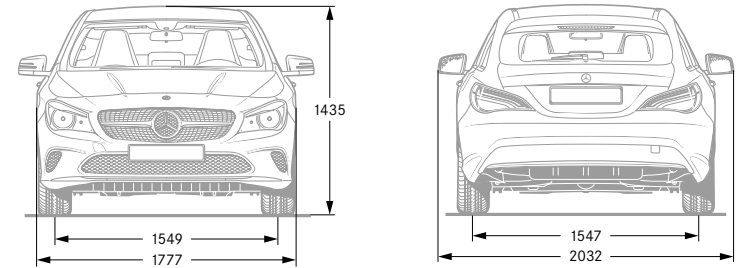

All dimensions in millimetres. The dimensions shown are mean values and apply to the standard-specification, unladen CLA 180.

# Upholstery and trim.

---

## Upholstery

---

- 111 ARTICO man-made leather in black<sup>1, 2, 4</sup>
- 118 ARTICO man-made leather in crystal grey<sup>1, 2, 4</sup>
- 151 ARTICO man-made leather in black<sup>1, 3, 4</sup>
- 155 ARTICO man-made leather in sahara beige<sup>1, 3, 4</sup>
- 158 ARTICO man-made leather in crystal grey<sup>1, 3, 4</sup>
- 351 ARTICO man-made leather / Coari fabric in black<sup>3</sup>
- 358 ARTICO man-made leather / Coari fabric in crystal grey<sup>3</sup>
- 371 ARTICO man-made leather / Maringá fabric in black with blue highlights<sup>3</sup>
- 378 ARTICO man-made leather / Maringá fabric in crystal grey<sup>3</sup>
- 381 ARTICO man-made leather / Maringá fabric in black with white highlights<sup>3</sup>
- 651 ARTICO man-made leather / DINAMICA microfibre in black<sup>3, 5, 6</sup>
- 801 Leather in black<sup>3</sup>
- 804 Leather in nut brown<sup>3</sup>
- 811 RED CUT leather in black<sup>3</sup>
- 855 Leather in sahara beige / black<sup>3</sup>

---

## Trim

---

- H06 Matt black ash<sup>1</sup>
  - H14 High-gloss brown burr walnut wood<sup>1</sup>
  - H19 Satin-finish light brown poplar wood<sup>1</sup>
  - H72 Dark honeycomb-grain aluminium<sup>1</sup>
  - H73 AMG carbon fibre<sup>1</sup>
  - H79 Light longitudinal-grain aluminium<sup>1, 7</sup>
  - H81 Sail pattern
  - H88 Matrix look
  - H90 AMG design in black/red<sup>6</sup> (not illustrated)
  - H91 AMG design in black/silver<sup>8</sup> (not illustrated)
  - H92 AMG DINAMICA microfibre in black<sup>1</sup>
  - 739 Trapezium-grain aluminium<sup>1, 9</sup>
- 

<sup>1</sup> Optional extra. <sup>2</sup> Luxury seat. <sup>3</sup> Sports seat. <sup>4</sup> Only in conjunction with Seat Comfort package. <sup>5</sup> Standard for Sport model. <sup>6</sup> Standard for Mercedes-AMG models.  
<sup>7</sup> Standard in conjunction with AMG Line and AMG Exclusive package. <sup>8</sup> Optional extra for Mercedes-AMG models. <sup>9</sup> Standard in conjunction with Exclusive package.

## Standard equipment

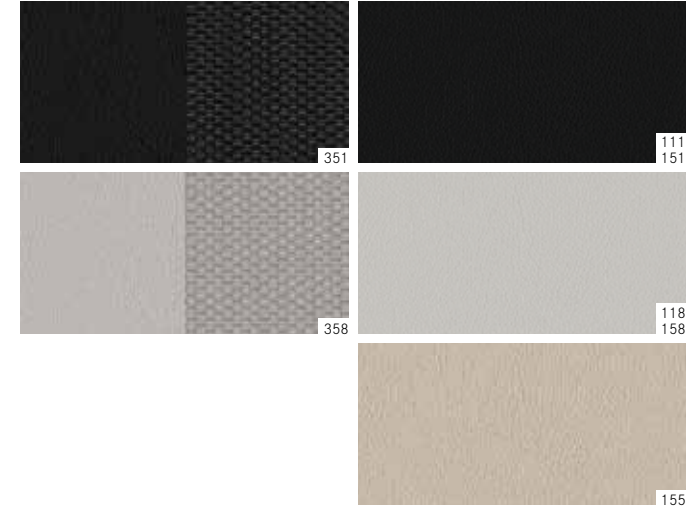

Urban line<sup>1</sup>

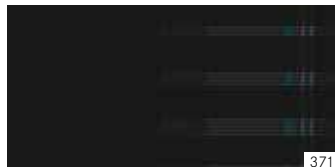

371



111  
151



381

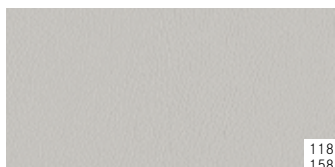

118  
158

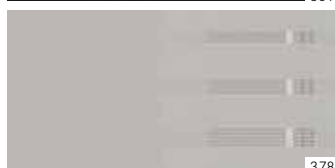

378



155



H81



H79

AMG Line<sup>1</sup>



651



H79



H72



H73



H92

Exclusive package<sup>1</sup>

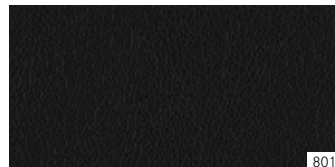

801



804



855



H06



H14

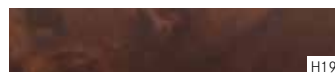

H19



739



H79



H72



H73



H92

AMG Exclusive package<sup>1</sup>



811



H79



H72



H73



H92



# Paintwork.

## Non-metallic paints



589

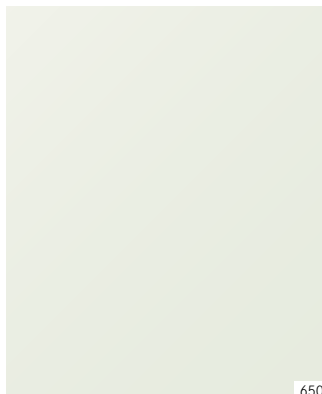

650



696

## Metallic paints<sup>1</sup>



191



761



787



890



990

## Special paint<sup>1</sup>



991

---

### Non-metallic paints

---

589 jupiter red

650 cirrus white

696 night black

---

### Metallic paints<sup>1</sup>

---

191 cosmos black

761 polar silver

787 mountain grey

890 cavansite blue

990 orient brown

---

### Special paint<sup>1</sup>

---

991 designo polar silver magno

<sup>1</sup> Optional extra.



**Mercedes-Benz is one of the founding partners of the “Laureus Sport for Good Foundation”.**

Since the foundation was established in 2000, Mercedes-Benz has been supporting and promoting the aims and values of this worldwide non-profit-making programme: to use social sports projects to improve the lives of children and young people who are disadvantaged or suffering from illness. Laureus has become a fundamental element of Mercedes-Benz’s social responsibility. Every new Mercedes is an ambassador embodying these values. In buying a Mercedes you are supporting the “Laureus Sport for Good Foundation”.

**Please note:** changes may have been made to the product since going to press (17.02.2016). The manufacturer reserves the right during the delivery period to make changes to the design, form, colour or specification, provided these changes, while taking into account the interests of the vendor, can be deemed reasonable with respect to the purchaser. Where the vendor or the manufacturer uses symbols or numbers to describe an order or the subject of an order, no rights may be derived solely from these. The illustrations may include accessories and optional extras which do not form part of the standard specification. Actual colours may differ slightly from those shown owing to the limitations of the printing process. This brochure is distributed internationally. Information given regarding statutory regulations, legal requirements and taxation and the consequences thereof applies to the Federal Republic of Germany only and is correct at the time of going to press. For current and more specific information in relation to the range of models, features, optional extras, colours and/or services available in your country, and their pricing, you should contact your nearest authorised Mercedes-Benz Passenger Car Dealer.

[www.mercedes-benz.com](http://www.mercedes-benz.com)

**Take-back of end-of-life vehicles.** You can return your CLA to us for environment-friendly disposal in accordance with the European Union (EU) End-Of-Life Vehicle Directive. But that day lies a long way off.

A network of vehicle take-back depots and dismantlers has been established to make it as easy as possible for you to return your vehicle. You can leave it at any of these points free of charge and, by so doing, make an important contribution to completing the recycling process and conserving resources.

For further information about the recycling and disposal of end-of-life vehicles, and the take-back conditions, please visit the national Mercedes-Benz website.